

# Installation and Maintenance Instructions

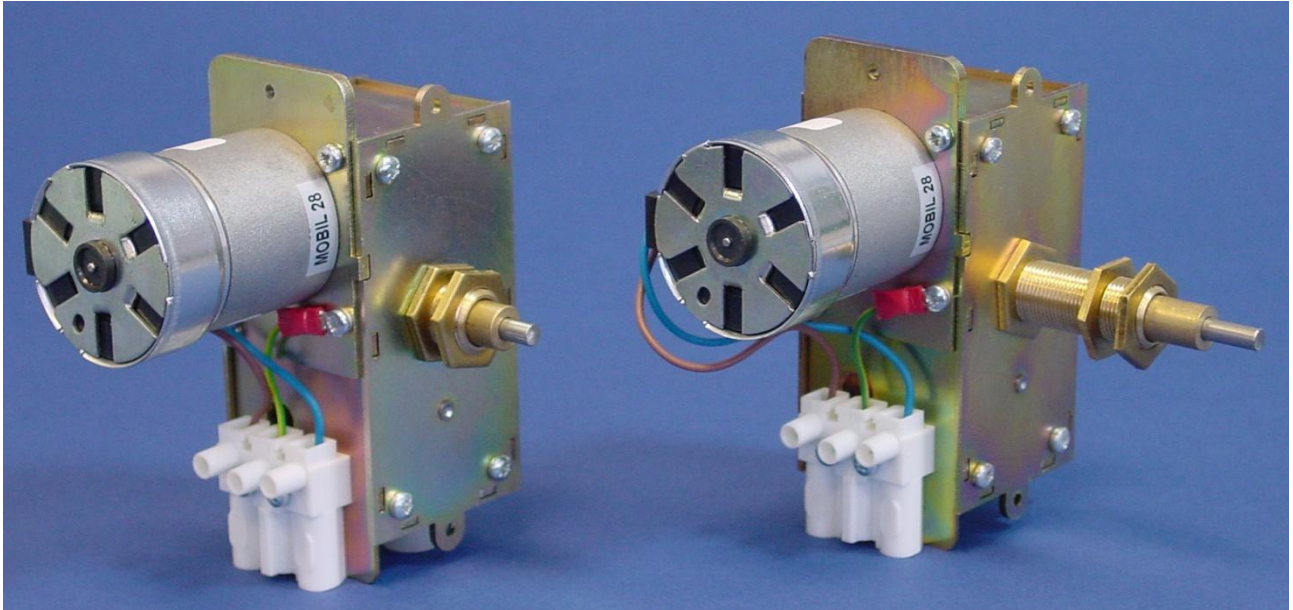

## T100 Movements

With A or B type centre fixing threaded support tubes

ISSUE DATE 16 FEBRUARY 2011

Dimensions, specification	page 2
Installation	page 3
Fitting the Hands	page 5
Wiring	page 6
Setting to time	page 6
Lubrication	page 7
Motor replacement	page 8
Site information details form	page 8

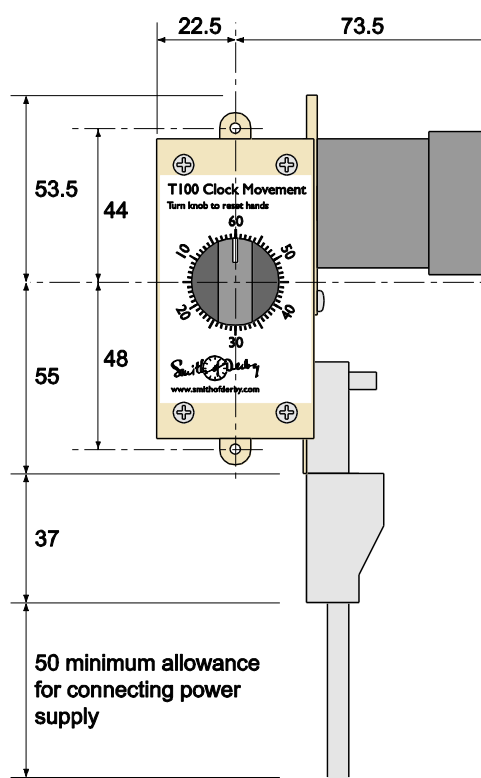
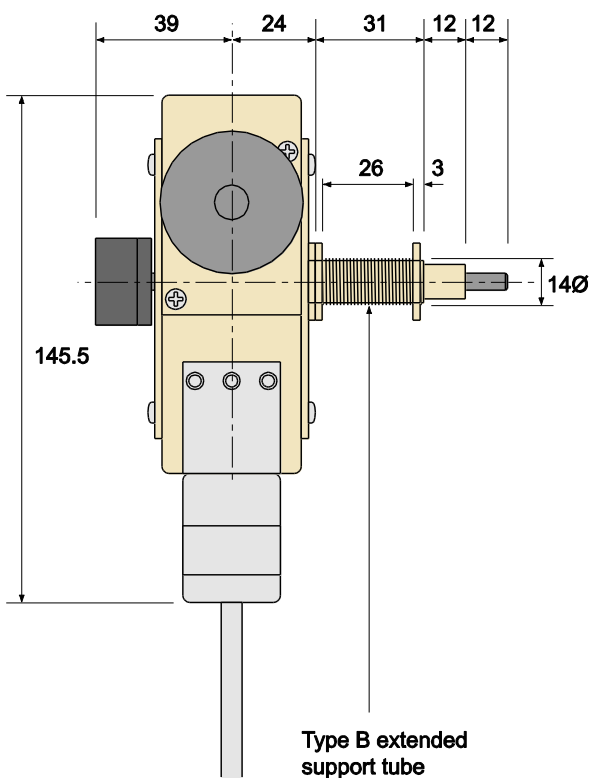
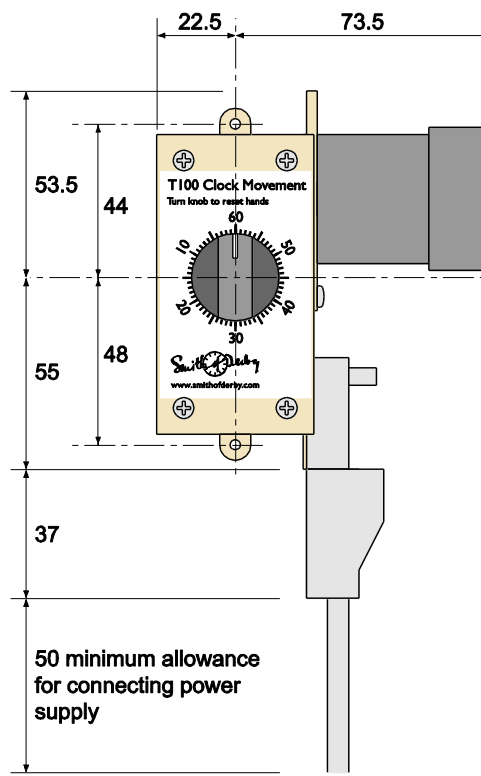
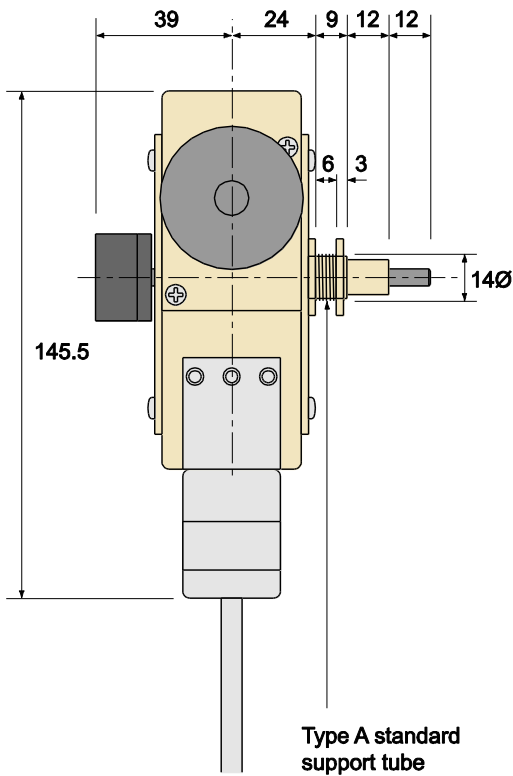

**T100 overall dimensions.**

- Weight: (excluding hands): 0.65kg.
- Maximum dial diameters: 750mm exterior, 900mm interior or enclosed behind cover glass.
- Power requirements: 230V AC, 50Hz (110V and/or 60Hz to special order) fused at 3A.
- Power consumption: 3W.

Materials: corrosion resistant plated steel casing, pre-lubricated long life bearings, precision machined brass gear wheels and bronze bearings.

# INSTALLATION

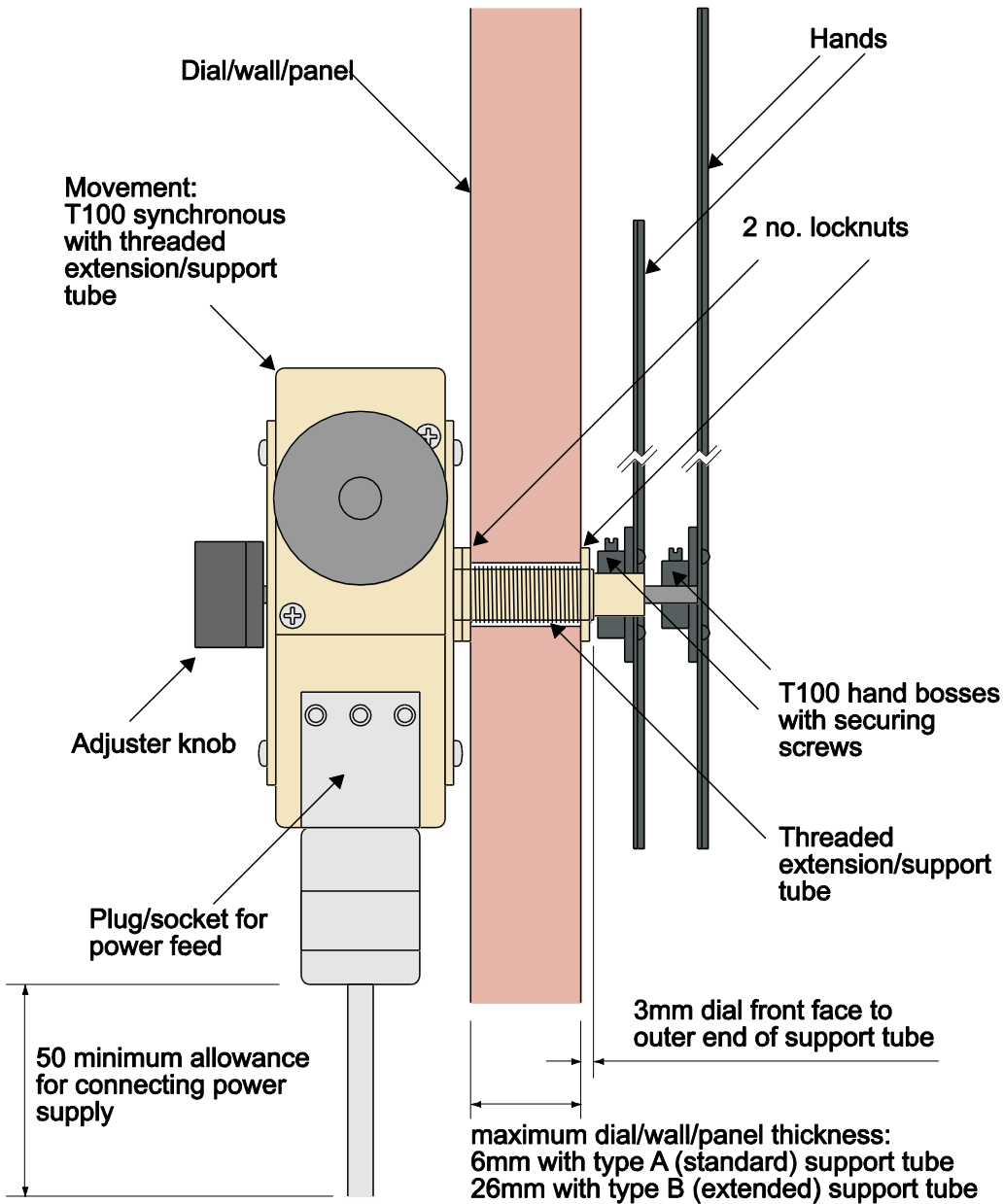

## T100 centre fixing sectional diagram.

The T100 movement is held in position using locknuts on the threaded extension/support tube.

The type A (standard) support tube version is suitable for dials up to 6mm thick.

The type B (extended) support tube version is suitable for dials up to 26mm thick, or for thinner dials which have backlighting, when the movement body is set back from the dial to minimise shadow. See diagram on page 4.

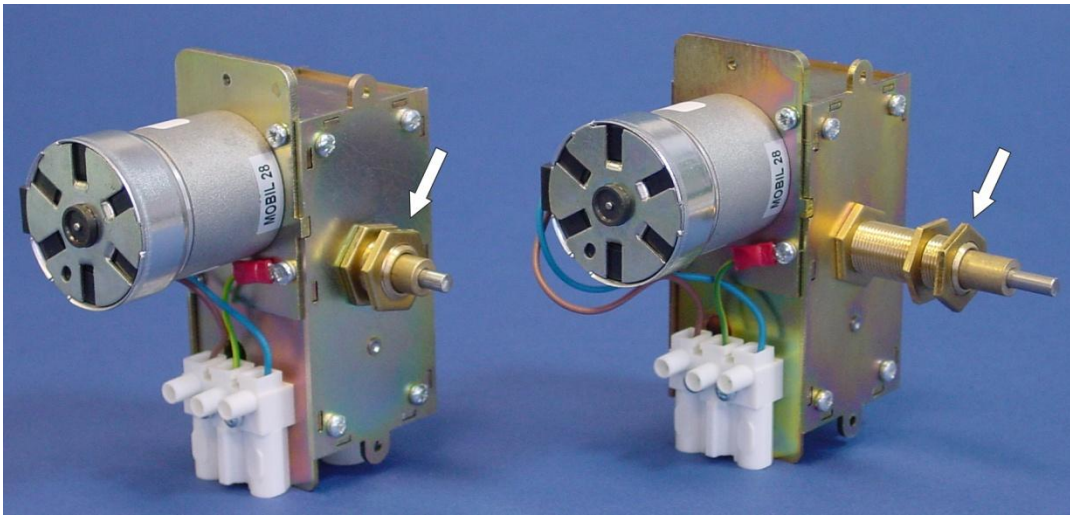

Remove the locknut on the threaded tube (outer of 2 locknuts on type B extended version).

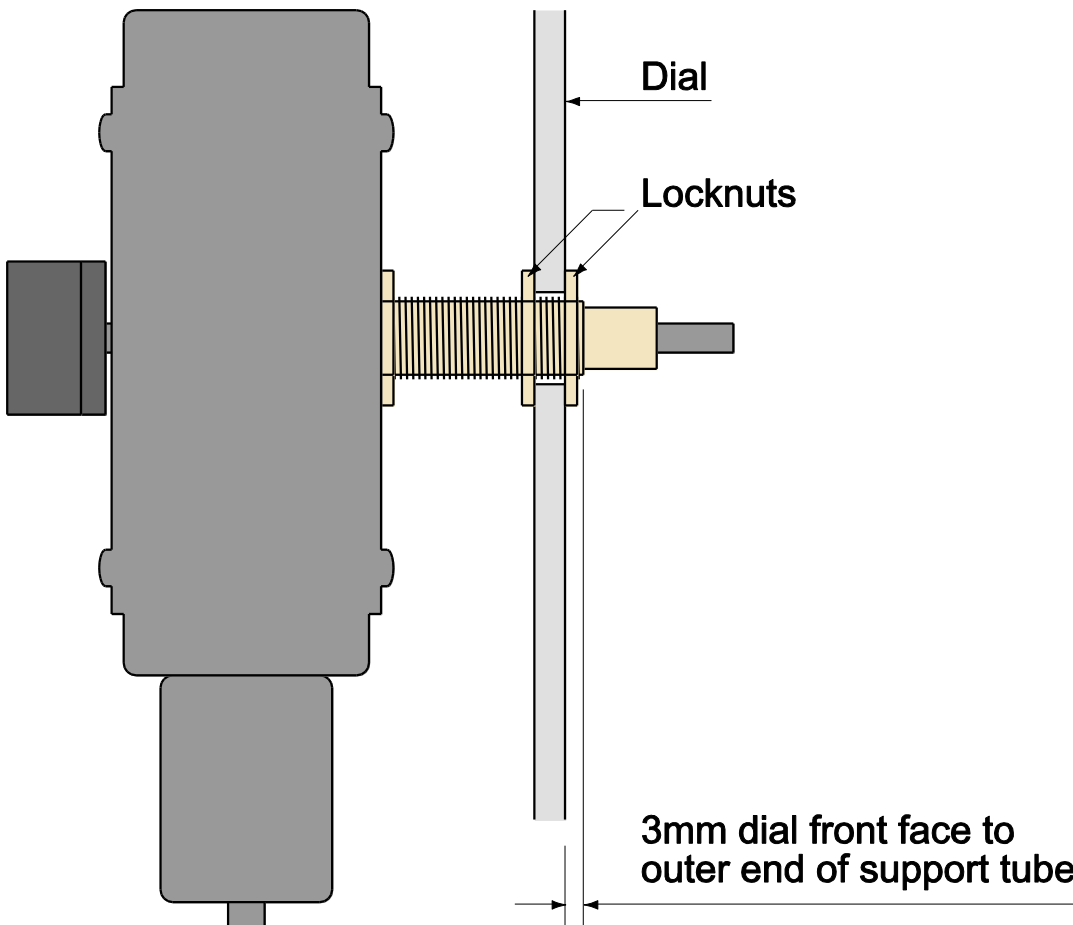

Insert the tube into a pre-drilled 14mm clearance diameter hole in the dial, wall or panel.

On the type B extended version set the inner locknut to give the minimum 3mm projection from the outer face of the dial.

The movement is secured in place by tightening the outer locknut.

## FITTING THE HANDS

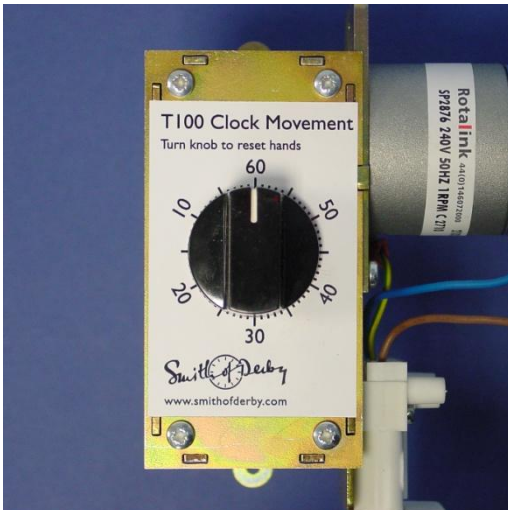

Set the indicator on the back of the movement to 60.

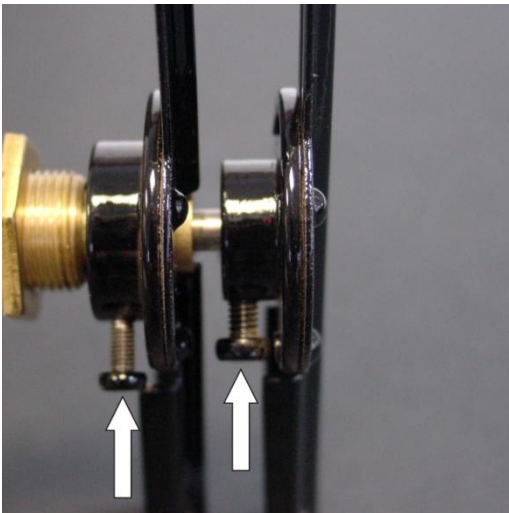

Fit the hour hand to the hour hand drive spindle. Set so that it is pointing vertically, to 12.00. Tighten the securing screws on the boss.

Fit the minute hand in the same way. Make sure that both hands are set perfectly vertical.

Check that the hands will not catch on any part of the clock dial area when operating. If possible, adjust the forward projection of the T100 using the locknuts on the threaded extension/support tube.

## WIRING

Connect to a Smith of Derby Power Failure Back-up System (ARU or ICU) for full automatic control of the clock/s. See separate wiring diagram supplied with the Power Failure Back-up System.

Alternatively connect directly to the mains supply via a 3-A switched fused spur which must be adjacent to the T100 movement. NOTE: timekeeping relies on mains frequency. We do not recommend connecting directly to a circuit where frequency may vary such as with a standby generator.

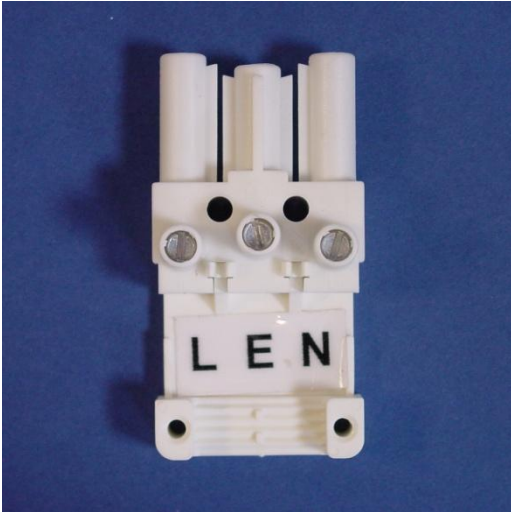

Connect the power supply to the separate plug supplied. Follow the polarity marked on the plug.

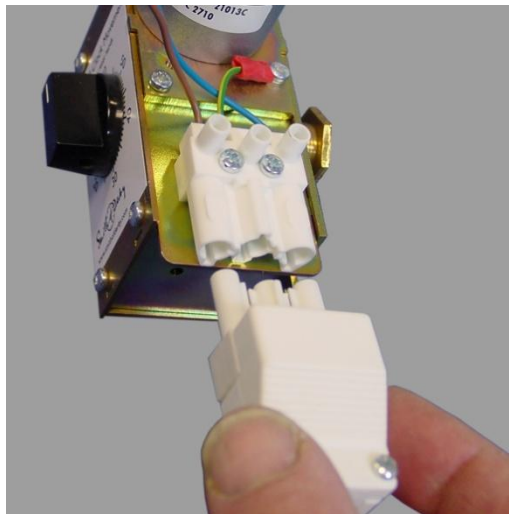
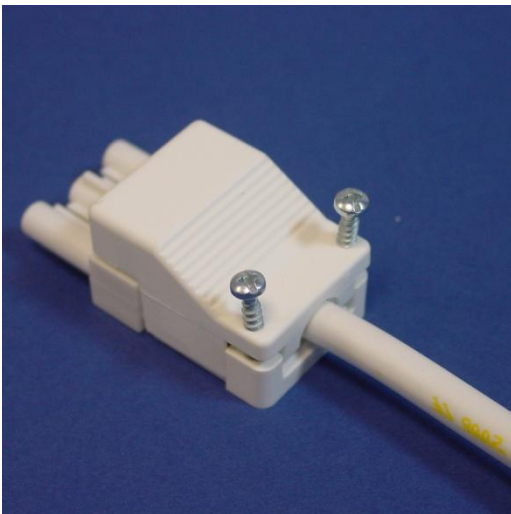

Fit the plug cover/cable grip and insert the plug.

## SETTING TO TIME

**AUTOMATIC START-UP:** if the movement is to be wired to a Smith of Derby Power Failure Back-up System then the system will automatically start the clock at 12.00 mid-day local time after power has been connected.

Only re-set the time manually if a different time is to be shown on the dial. For example, for a set of clocks showing five different world times, set each dial at the exact required hour ahead or behind 12.00 mid-day local time to correctly configure them ready for automatic start-up.

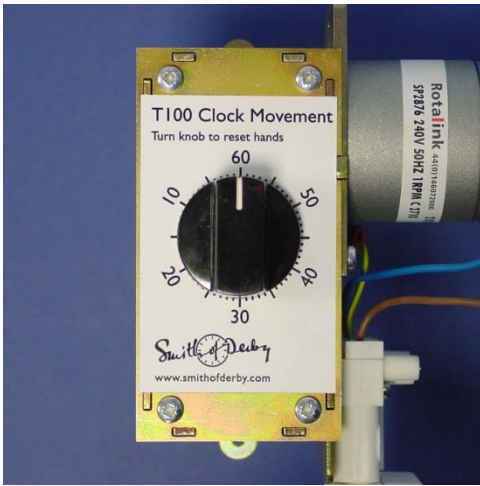

MANUAL SETTING: turn the knob on the back of the T100: one full turn per hour and a part turn for the required number of minutes. Note that the time reads anti-clockwise. The knob will turn in either direction.

Alternatively, gently turn the minute hand in either direction by pushing at the tip. DO NOT attempt to alter the time by turning the hour hand. If hands are finished in gold leaf, WEAR COTTON GLOVES to avoid discolouration of the gold.

## LUBRICATION

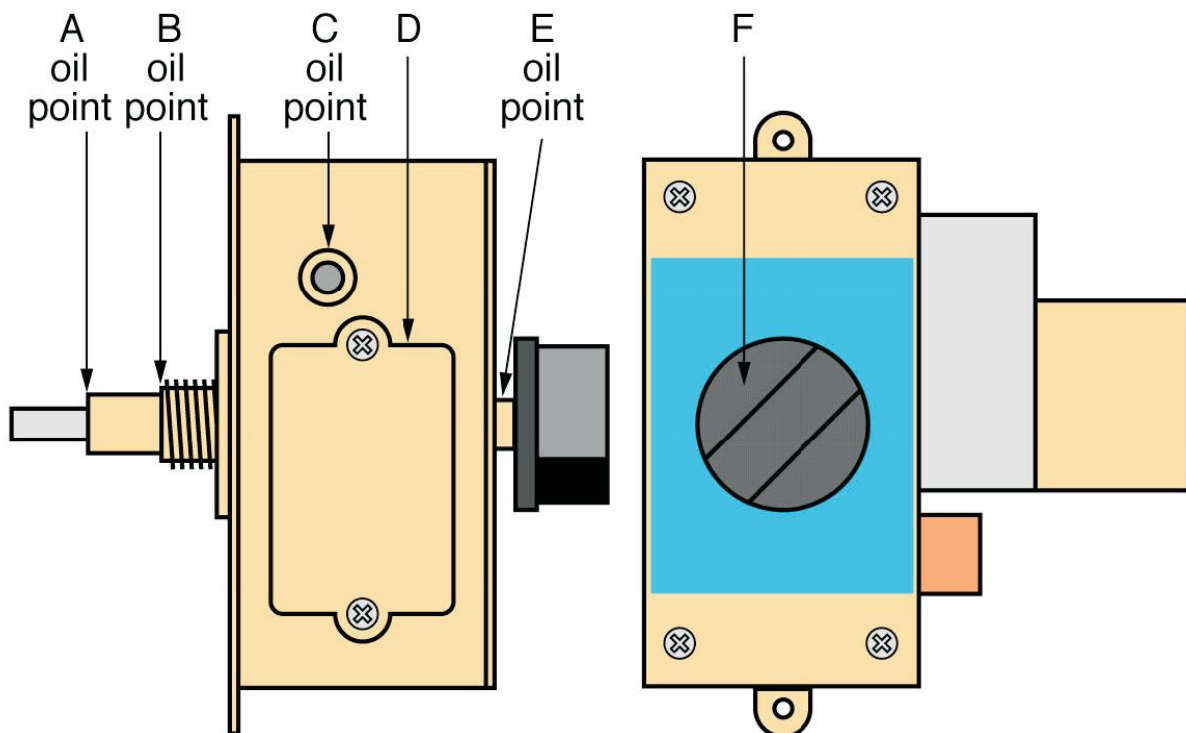

This clock movement should be lubricated every year by a clockmaker, a specialist engineer or by a person who has received training during our installation.

- 1 Oil the four oil points (A,B,C,E) then wipe off excess.
- 2 To grease the worm remove the access-panel 'D' which is situated on side of the clock and apply 2ml of Omega 77 grease to the worm.
- 3 The oil that we recommend is Omega 646.
- 4 The grease that we recommend is Omega 77 (worm wheel only).

## MOTOR REPLACEMENT

1. Isolate the power at the supply.
2. Disconnect the power supply plug on the T100.
3. Disconnect the three connections on the terminals of the socket.
4. Remove the two screws that secure the motor to the clock case.
5. Withdraw the motor / worm shaft assembly.
6. Remove the worm shaft from the motor.
7. Fit worm shaft assembly to the replacement motor.
8. Slide motor / worm shaft assembly into the clock case.
9. Secure motor gear box to clock case with the two screws.
10. Reconnect the motor wires to the terminals and reconnect the power supply plug.
11. Turn power back on.
12. Set to time.

The unit is fitted with lubricated for life bearings on the main shaft.

## SITE INFORMATION AND CONTACT DETAILS

For future client and engineer reference, please record the following details:

Site name where clock is located .....

Smith of Derby Group local representative:

Name.....

Tel.....Fax.....

Email .....

Local person in charge of this system:

Name.....

Address.....

.....Postcode.....

Tel.....Fax.....

Email .....

Other details:

.....



SMITH OF DERBY LTD

112 Alfreton Road, Derby DE21 4AU, UK

Tel +44 (0)1332 345569

www.smithofderby.com